

[72] Inventors **Edward Fredkin;**  
**Marvin L. Minsky, both of Brookline,**  
**Mass.**  
 [21] Appl. No. **11,683**  
 [22] Filed **Feb. 16, 1970**  
 [45] Patented **Oct. 5, 1971**  
 [73] Assignee **Triadex Incorporated**  
**Brookline, Mass.**

3,499,091 3/1970 Bunger ..... 84/1.03  
 3,499,092 3/1970 Bunger ..... 84/1.03  
 3,518,352 6/1970 Plunkett ..... 84/1.03

**OTHER REFERENCES**

"Build the Psych-Tone," Popular Electronics, Feb. 1971, pp. 25-35.

Primary Examiner—D. F. Duggan  
 Assistant Examiner—Stanley J. Witkowski  
 Attorney—Kenway, Jenney & Hildreth

[54] **DIGITAL MUSIC SYNTHESIZER**  
 19 Claims, 6 Drawing Figs.

[52] U.S. Cl. .... 84/1.03  
 [51] Int. Cl. .... G10f 1/00,  
 G10h 5/00  
 [50] Field of Search ..... 84/1.01,  
 1.03, 1.22, 1.26

[56] **References Cited**  
 UNITED STATES PATENTS

Re. 26,521 2/1969 Park ..... 84/1.03  
 3,358,068 12/1967 Campbell ..... 84/1.01  
 3,478,633 11/1969 Mallett ..... 84/1.03  
 3,482,027 12/1969 Okamoto et al. .... 84/1.03

**ABSTRACT:** In the apparatus disclosed herein, a note generator is controlled by a long term, quasi-periodic function which is in turn generated by applying digital feedback in preselected combinations around a digital register. The register comprises means for holding a plurality of bits of digital information in a given order, e.g. a shift register or counter, the held information being changeable according to a predetermined pattern in response to input signals applied thereto. Digital feedback is provided by applying to the register at least one input signal which is obtained according to a preselectable or adjustable code from bits of information obtained from various points in the register itself. The apparatus thus, in effect, composes music as distinguished from merely synthesizing sound.

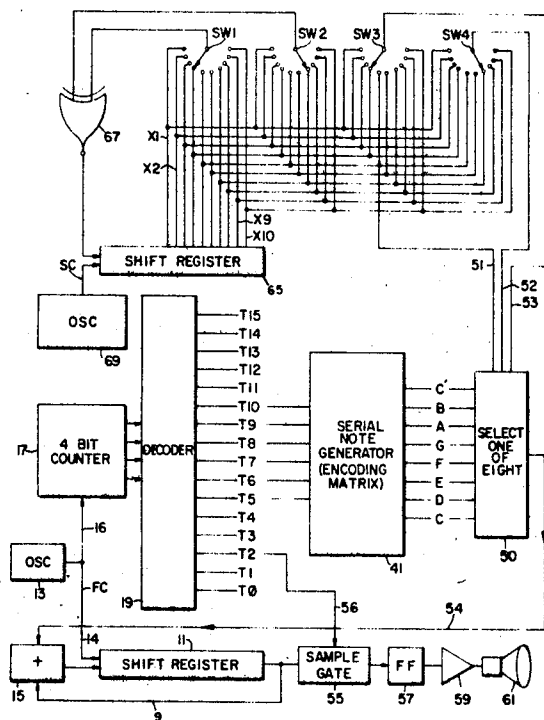

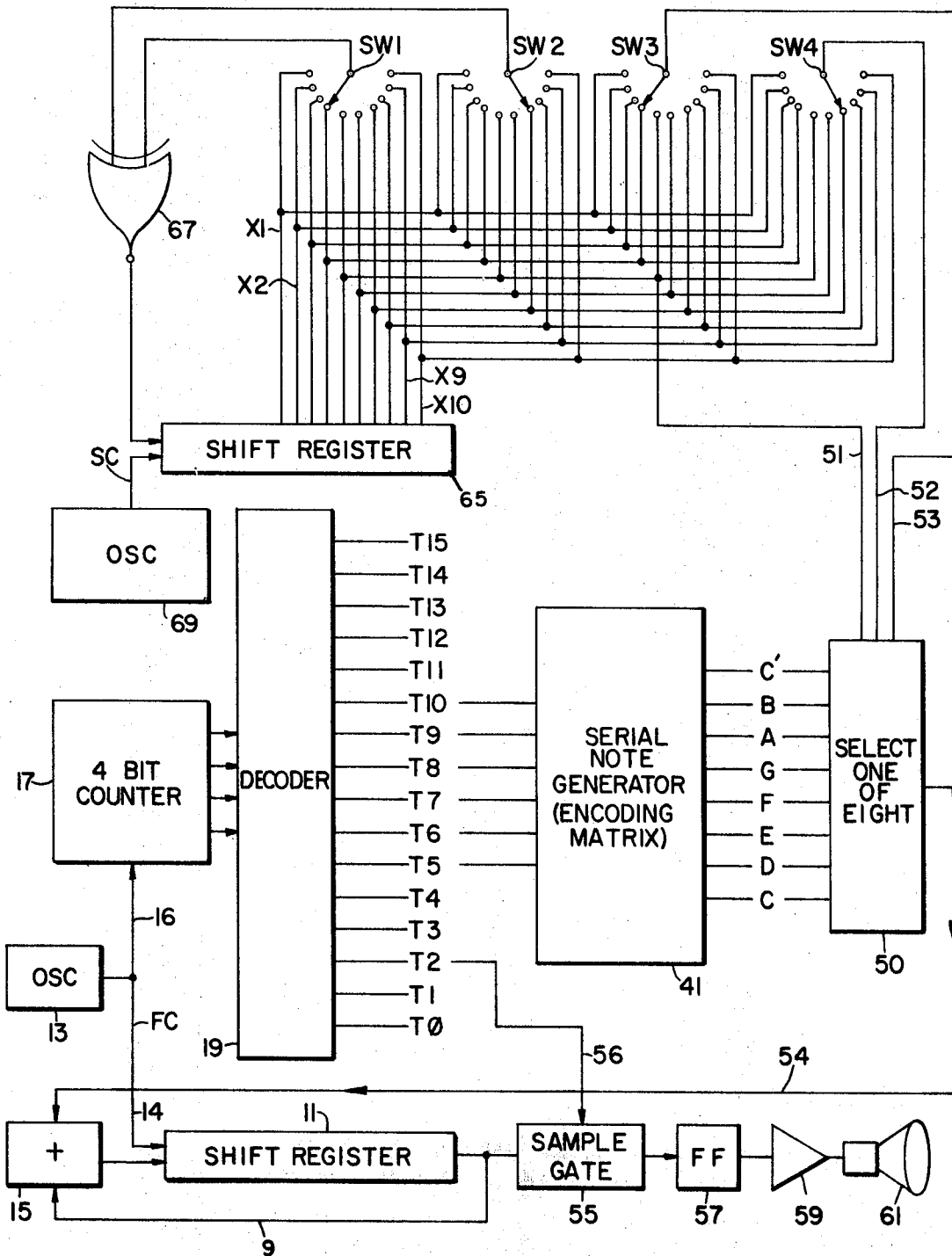

FIG. 1

INVENTORS  
 EDWARD FREDKIN  
 MARVIN L. MINSKY

BY  
*Kenway, Jenney + Hildebreth*  
 ATTORNEYS

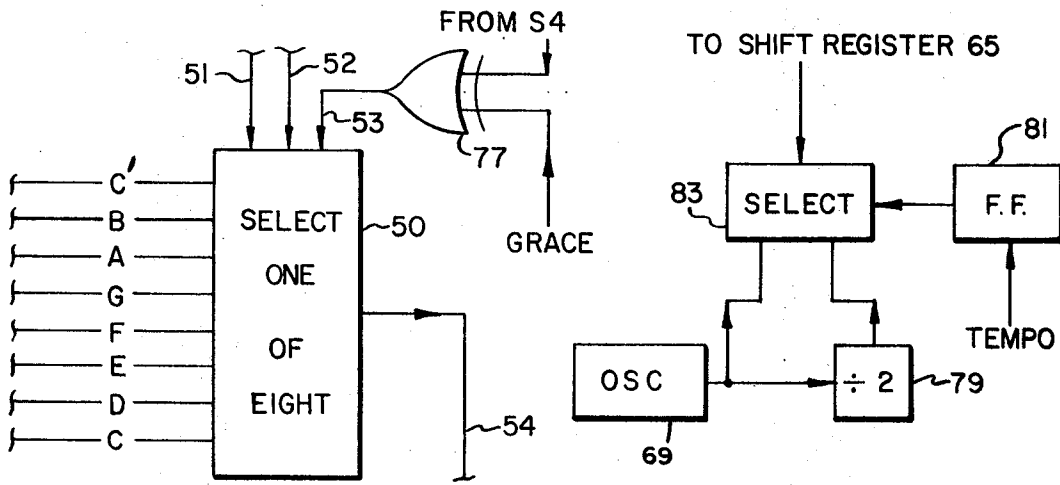
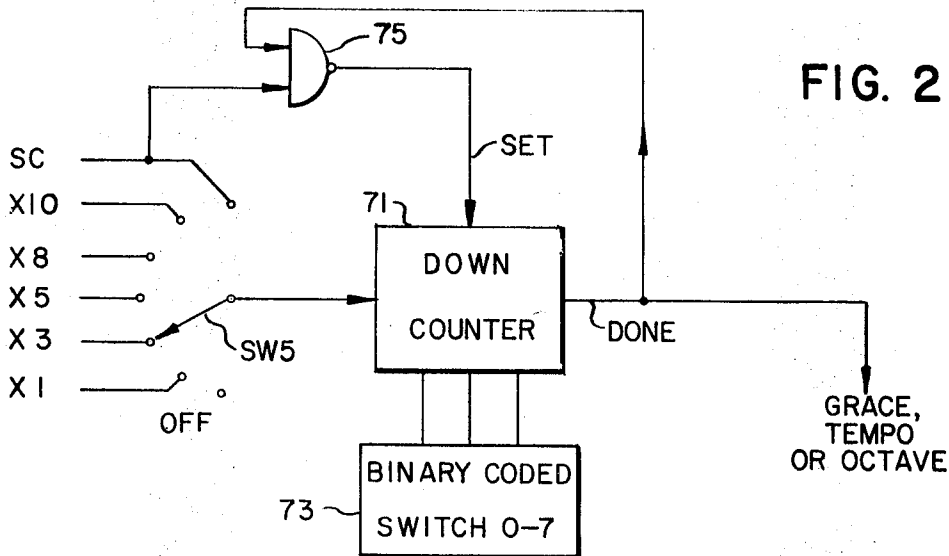
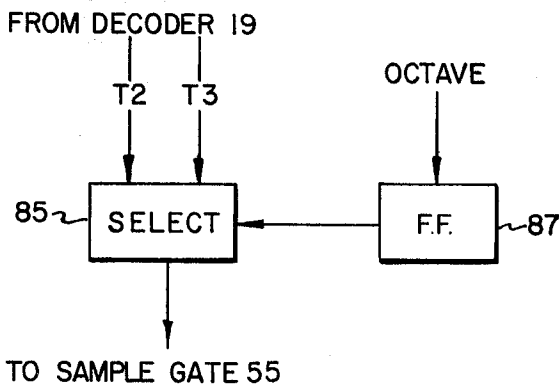

FIG. 4



INVENTORS  
EDWARD FREDKIN  
MARVIN L. MINSKY

BY

*Kenway, Janney & Hildebreth*  
ATTORNEYS

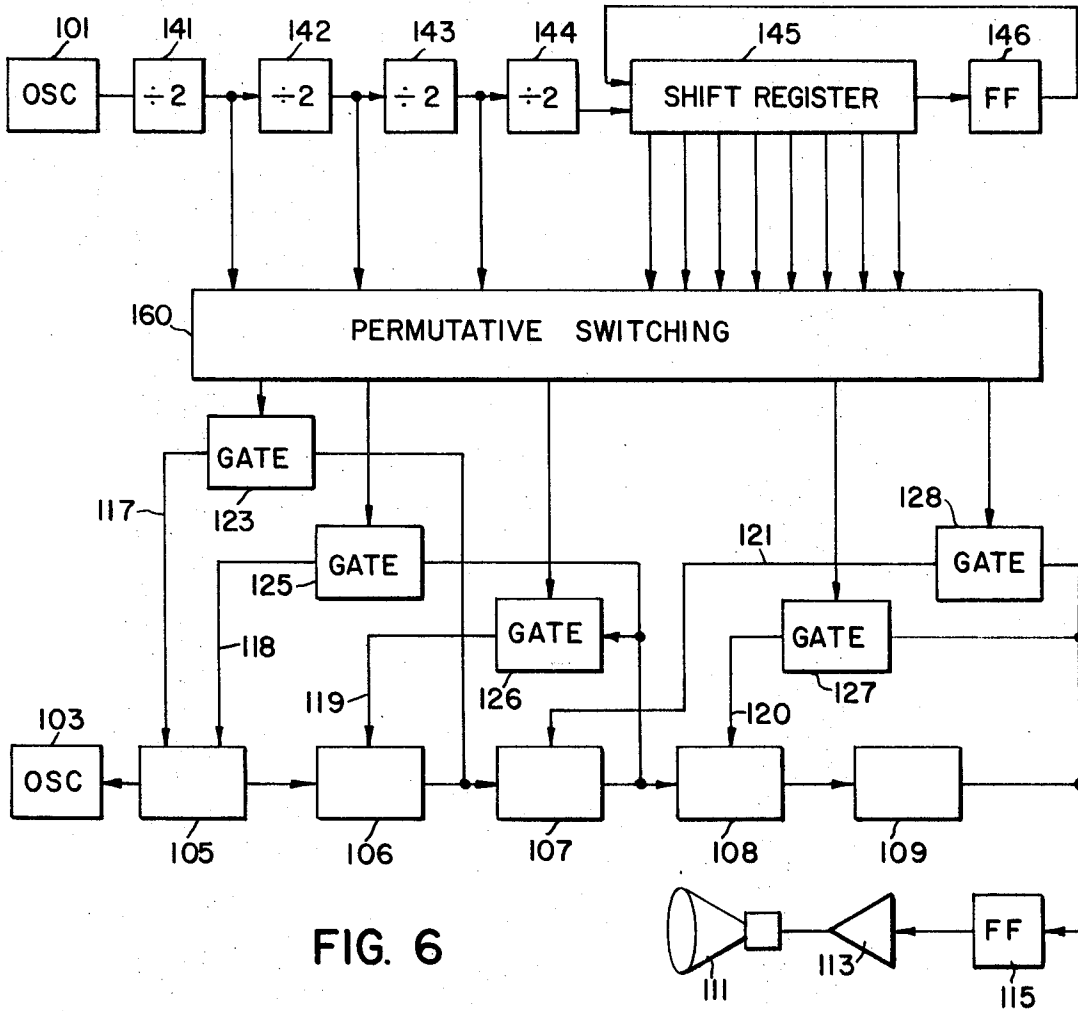

FIG. 6

INVENTORS  
EDWARD FREDKIN  
MARVIN L. MINSKY

BY

*Henway, Jenney & Hildebreth*

ATTORNEYS

## DIGITAL MUSIC SYNTHESIZER

## BACKGROUND OF THE INVENTION

This invention relates to apparatus for making music and more particularly to such apparatus employing digital logic elements.

In recent years substantial efforts have been directed toward developing apparatus and/or methods for generating or composing music synthetically, that is, with a human operator imposing only minimal constraints on the form of the composition and with the details of note sequence and rhythm being provided automatically. Typically, these efforts have involved the use of a relatively large, general purpose computer, i.e. one utilizing a stored program. To this end, considerable effort has been expended in analyzing various types of music and in attempting to determine the requisites for pleasing music. These requisites have then been incorporated into the music composing program in keeping with various statistical methods and approaches. In one such prior art method of generating music, various elaborate constraints are imposed upon the output of a program which is itself designed to generate a sequence of numbers having a very high degree of randomness.

In accordance with one of its aspects, the present invention utilizes an understanding or appreciation that a very high degree of randomness is not necessary but rather it is preferable to generate logical sequences of notes or musical sounds having a very long period of repetition. As will be apparent hereinafter, this understanding facilitates the construction of relatively simple apparatus which nonetheless automatically generates relatively pleasing music.

Among the several objects of the present invention may be noted the provision of apparatus for automatically generating pleasing sequences of musical notes or sounds; the provision of such apparatus which is capable of generating a wide variety of such sequences or compositions with the exercise of only minimal control by a human operator; the provision of such apparatus which is easy to operate; the provision of such apparatus which is compact and requires little power; the provision of such apparatus which is reliable and which is relatively simple and inexpensive. Other objects and features will be in part apparent and in part pointed out hereinafter.

## SUMMARY OF THE INVENTION

Briefly, apparatus constructed in accordance with the present invention is adapted to make or compose music, that is, to generate pleasing sequences of musical notes or sounds. The apparatus employs tone generating means operative to provide a variety of musical notes in response to predetermined combinations of control signals applied thereto. A register is provided which includes means for holding a plurality of bits of digital information in a given order, the held information being changeable according to a predetermined pattern in response to input signals applied to the register. Associated with the register are means for reading the held digital information at a plurality of selected points in the register. At least one of the input signals applied to the register is obtained according to a preselectable or adjustable code from bits of information read out of the register. Another input signal applied to the register varies according to a predetermined periodic function. The tone generating means is then operated in response to control signals which vary as respective preselectable logic functions of the information held in the register.

## BRIEF DESCRIPTION OF THE DRAWINGS

FIG. 1 is a block diagram of music making apparatus constructed in accordance with the present invention employing digital electronic circuitry;

FIG. 2 is a block diagram of a counting circuit useful with various modifications of the apparatus of FIG. 1, e.g. those illustrated in FIGS. 3-5, to provide added varieties of musical form;

FIG. 3 is a block diagram of an alternative form of sequence generating circuitry which may be employed with the apparatus illustrated in FIG. 1 to provide grace notes;

FIG. 4 is a block diagram of an alternate rhythm generating circuit which may be employed with the apparatus illustrated in FIG. 1;

FIG. 5 is a block diagram of an alternate note selection circuit which may be employed with the apparatus illustrated in FIG. 1 to provide octave shifts in tone; and

FIG. 6 is a block diagram of another embodiment of the invention, also employing digital circuitry.

Corresponding reference characters indicate corresponding parts throughout the several views of the drawings.

## DESCRIPTION OF THE PREFERRED EMBODIMENT

Referring now to the FIG. 1 apparatus, the note or tone generating portion of the circuit includes a 16 bit shift register 11 which is operated as a serial accumulator in conjunction with a single bit adder 15 for determining or controlling the frequency of the note being generated. While serial operation has been shown by way of illustration, it should be understood that parallel operation can also be used. An adjustable oscillator 13 generates a square-wave clock signal which is applied to the shift input terminal of register 11, through a line 14, for periodically shifting data held in the register. The signal generated by oscillator 13 is at a relatively high frequency, i.e. at a multiple of the highest tone frequency which is to be generated, and is designated the fast clock signal FC.

Data spilled over from the last stage of register 11 as a result of shifting is applied to the adder 15 through line 9 as one of its input signals and the output signal from the adder is applied to the input terminal of the register 11. Register 11 and adder 15 thus form a 16-bit serial accumulator as will be understood by those skilled in the art. In other words, a binary number circulating through the register 11, can be cumulatively increased by applying an appropriate binary signal to the other input terminal of adder 15 in appropriate serial format. The circulating binary number is conveniently designated the sum or accumulated total. As will be apparent hereinafter, the period required to circulate the 16-bit sum number through the register 11, i.e. a period equal to 16 times the period of oscillator 13, forms a basic timing interval of the entire apparatus.

The fast clock signal from oscillator 13 is also applied, through a lead 16, to a four-bit counter 17. Output signals from each stage of counter 17 are applied to a decoding matrix 19 which provides, at sixteen respective output terminals, pulse signals (I $\Phi$ -T15) which occur during successive states of the counter 17. Counter 17 and decoder 19 thus in one sense provide a function or operation similar to that of a ring counter and the various timing pulses T $\Phi$ -T15 serve to identify particular bit positions within the binary "word" being circulated within the serial accumulator which includes register 11. Not all of these signals are used, however, as will be apparent hereinafter.

Selected ones of the timing pulses, i.e. T5-T10, are applied to an encoding matrix 41. Matrix 41 combines the timing pulses T5 and T10 in various combinations so as to provide on each of eight output leads a serial binary signal which represents a number defining the frequency of a corresponding musical note or tone with the desired degree of accuracy. The various leads correspond to the musical notes C, D, E, F, G, A, B and C' and are identified accordingly. Matrix 41 thus functions as a serial note generator. The serial format in which the note frequency numbers are encoded is chosen to correspond with the format used in the serial accumulator which includes adder 15 and shift register 11. One of the eight note signals is selected by a conventional selection gating circuit 50 in response to a three-bit binary selection signal applied thereto through leads 51-53. The selected note signal is then applied to the remaining input of adder 15 through a lead 54.

From the foregoing, it will be apparent to those skilled in the art that a number representing the frequency of a selected

musical note is repetitively added to the sum being circulated through register 11. As the numbers being added occupy only bit positions corresponding to the timing pulses T5-T10, it can be seen that the more significant bit positions hold only data which represents the accumulation of carry signals from the repetitive addition. Given the fact that the repetitive addition proceeds on a regular basis or frequency under the control of oscillator 13, it can be shown that each of the more significant bit positions in the circulating sum is itself a signal having a frequency which is substantially proportional to the selected note frequency, i.e. as designated by the signals formed by matrix 41. There is some short-term error or jitter but the long-term proportionality is substantially exact.

In the embodiment illustrated, the sum number circulating around register 11 is sampled during the T2 pulse interval by means of a sampling gate 55, the T2 pulse from decoder 19 being applied to gate 55 through a lead 56 for this purpose. The sampled signal is applied to a flip-flop 57 to obtain a symmetrical square-wave signal which represents the state of the selected bit in the circulating sum. This square-wave signal is then amplified, as indicated at 59, and applied to a loudspeaker 61. Loudspeaker 61 will thus produce a tone or musical sound having a basic frequency component which is proportional to the selected note frequency as defined by the matrix 41. This note is also proportional in frequency to the frequency of oscillator 13. Thus, by varying or adjusting of the output frequency of oscillator 13 the pitch of the notes being generated may be scaled upwards or downwards as desired. The ratio in frequency between one selected note and the next will, however, remain unchanged since this proportionality is determined by the frequency numbers which are defined by the encoding matrix 41.

The portion of the FIG. 1 apparatus which determines the sequence in which notes are played includes a shift register 65 of suitable length, e.g., 32 bits. A second adjustable oscillator 69 provides a second timing signal, designated the slow clock signal, which is applied to the shift control terminal of register 65. Data held in register 65 is thus periodically shifted. Signals taken from various selected stages of shift register 65 are applied to the selection terminals of each of four separate single-pole, ten-position switches SW1-SW4. These signals are designated X1-X10. The first two switches SW1 and SW2 control the application of digital feedback around the shift register 65, the signals selected by these switches being combined in an EXCLUSIVE OR gate 67 with the output signal from gate 67, or its complement, being applied as the input signal to the shift register. Thus, as the existing data held in the shift register 65 is periodically shifted under the control of oscillator 69, the new data being introduced into the register depends upon or is a logical function of bits of information obtained from the register itself at selected points. As will be apparent to those skilled in the art, register 65 will therefore operate to generate a relatively complicated binary sequence which may have a very long period of repetition, depending upon the settings of the switches SW1 and SW2. The complexity and length of the pattern produced can be increased if desired by increasing the number of components which are combined, e.g., by adding additional switches to switches SW1 and SW2, and by varying the combination arrangement, e.g., by using other and more complicated logic functions in place of the EXCLUSIVE OR. If desired, means may also be provided for preloading the register so as to define the starting point in the sequence or function and to permit sequences to be duplicated.

The signals selected by the other two switches SW3 and SW4 are applied, through leads 52 and 53, as two of the three signals which control the note-selecting gate circuit 50. The other control signal, applied through lead 51, is obtained from a fixed one of the points in shift register 65. It can thus be seen that the note being played at any given moment will be determined as a preselectable logical function of the information held in register 65, the particular function being dependent upon the setting of the switches S3 and S4. As the data held in

register 65 is periodically shifted under the control of oscillator 69, the note being played will change in a sequence which depends both upon the setting of the switches S3 and S4 and the particular pattern or sequence of binary signals being generated by the shift register 65 in response to the particular settings of switches S1 and S2. The frequency with which the note being played is changed will, of course, depend upon the frequency of operation of oscillator 69. In other words, oscillator 69 determines the basic tempo. Thus, the tempo may be adjusted, without affecting the pitch of the notes being played, by varying the frequency of operation of oscillator 69. While the frequency of operation of oscillator 69 determines basic tempo, it should be understood that the note being played will not necessarily change pitch once for each cycle of the oscillator. Although the binary pattern or sequence produced by the register 65 will typically continue for a relatively long interval without repeating, various intervals may frequently occur in which there is no change in the particular bits used for note selection. In fact, this is preferably the case for pleasing music. Thus, though there is a possibility of a note change for each cycle of oscillator 69, the actual notes being played may persist for several of the basic beats determined by the oscillator. In other words, oscillator 69 determines the basic tempo but individual notes may last for different intervals. Thus, changing the settings of the switches SW1-SW4 will alter not only the sequence in which different notes are played but also the rhythm or patterns of note duration. As noted previously, though the sequences or patterns generated by the shift register are typically quite long, they are basically repetitive or periodic in nature and it has been found that, with only minor constraints on the selections made by the switches SW1-SW4, quite pleasing music is generated by the apparatus illustrated.

The musical themes or compositions generated by the apparatus of FIG. 1 can be further varied by including in the apparatus one or more of the modifier circuits illustrated in FIGS. 3-5, each of these modifier circuits being adapted for operation in association with a respective counting or control circuit such as that illustrated in FIG. 2. Referring now to FIG. 2, the slow clock signal SC and selected ones of the signals provided by the various stages of shift register 65 are provided to fixed positions or poles of a selector switch SW5. One of the switch positions is left unconnected to permit the respective modification circuit to be rendered inoperative.

The signal selected by switch SW5 is applied to a 3-bit down counter 71 which, as is explained hereinafter, controls the frequency of appearance of the respective theme modification. Down counter 71 is of the type which can be preset to a preselected value, e.g. a value determined by a 3-bit binary-coded switch as indicated at 73, upon application of a control signal to a SET input to the counter. Counter 71 is also operative to provide a DONE signal when the counter has counted back to zero from the selected preset value. The DONE signal and the slow clock signal SC are combined in a NAND gate 75 to provide a signal which controls the presetting of the counter. As will be understood by those skilled in the art, this feedback connection causes the down counter 71 to be preset to the preselected value on the next beat following that in which the DONE signal is initiated. Thus, after the selected event has occurred the preset number of times, a DONE signal is produced for a period of one beat. As noted previously, one circuit such as that illustrated in FIG. 2 is used with each of the modifier circuits and thus if all three modifier circuits are employed, three FIG. 2 circuits will be used with the apparatus of FIG. 1. The DONE signals from the FIG. 2 circuits are applied as the GRACE, TEMPO or OCTAVE Control signals indicated in FIGS. 3-5 respectively.

The modification illustrated in FIG. 3 effectively operates to provide a grace note at intervals or after sequences of events determined by the operation of the respective FIG. 2 counting circuit. The GRACE signal provided by the respective FIG. 2 circuit is combined in an EXCLUSIVE OR gate 77 with the signal obtained from the note sequence selector switch SW4 (Fig. 1), this being the signal which determines the least sig-

nificant bit in the 3-bit note selection code. The output signal from the gate is then applied to the note selection circuit 50 in place of that selector switch signal.

Since the operation of the exclusive OR gate 77 is to, in effect, complement the signal from switch SW4 whenever the GRACE signal is present, the note selection circuit 50, in effect, selects a note musically adjacent to that which would ordinarily be selected. Since the GRACE signal complements after an interval corresponding to one period of the slow clock oscillator 69, the "adjacent" note lasts for just one beat and the overall effect is that of providing a grace note.

In the modification illustrated in FIG. 4, the output signal from the slow clock oscillator 69 is applied to a divide-by-two counter or flip-flop 79 so as to obtain a half-frequency signal. The TEMPO signal from the respective FIG. 2 counting circuit is applied to trigger a flip-flop 81 which in turn controls a selection gate circuit 83. The selection gate circuit 83 permits either the direct or the half-frequency signal obtained from the oscillator 69 to be applied to the shift input terminal of register 65. Thus, whenever the respective FIG. 2 counting circuit generates a TEMPO signal, the flip-flop 81 is reversed in state so that the effective tempo or beat frequency is either doubled or halved depending upon the previous state of the flip-flop. In this way, the tempo of the music generated can be varied by a factor of two upon sequence of events predetermined by the operation of the respective FIG. 2 counting unit.

The modification illustrated in FIG. 5 operates to selectively change, by one octave, the overall musical pitch of the note sequence being generated. As will be understood by those skilled in the art, the effective frequency of the carry signal which is sampled from the sum number circulating through the serial accumulator can be effectively halved by selecting a bit in the sum number which is one place more significant than the original. Since the accumulator in the FIG. 1 embodiment operates in a serial mode, the bit selected can be varied by varying the sample timing. In the FIG. 5 modification, a selection gate circuit 85 is controlled by a flip-flop 87 so as to pass either the T2 timing pulse of the T3 timing pulse to the sampling gate 55. Flip-flop 87 is, in turn, controlled by the OCTAVE signal provided by the respective FIG. 2 counting unit. Accordingly, whenever the counting circuit generates an OCTAVE signal pulse, the state of the flip-flop 87 is reversed and the resulting change in sample timing causes the pitch of the note sequence being generated to change by one octave. The change will be up or down depending upon the previous state of the flip-flop 87.

Since the various theme modifications can be caused to occur frequently or infrequently as desired, e.g. by selecting low or high preset counts and by varying the type of input signal which increments the counter, it can be seen that considerable additional variation in the composition being generated is made possible by the variations illustrated in FIGS. 2-5.

While the embodiment illustrated in FIG. 1, employs shift registers both for determining the sequence of notes played and for synthesizing the frequencies or tones corresponding to these notes, suitable patterns and note frequencies can also be generated using multistage counters with selectively controllable digital feedback. Like a shift register, a multistage counting circuit with provision for feedback is a form of register comprising means for holding a plurality of bits of digital information in a given order. Further, the held information is likewise changeable according to a predetermined pattern in response to input signals applied to the register. In other words, a shift register is one particular kind of register and a multistage counter is another. FIG. 6 illustrates, in a general way, apparatus which employs counting registers with digital feedback in place of the shift register of FIG. 1.

As in the previous embodiments, the FIG. 6 arrangement employs a first oscillator 101 which acts as a slow clock and provides the basic timing unit for rhythm or note sequencing. A second oscillator 103 acts as a fast clock and provides a basic timing unit for frequency synthesis.

Oscillator 103 drives a succession of counting stages 105-109 which provide a maximum frequency division sufficient to reach the lowest note to be played. The last counting stage (109) drives a loudspeaker 111 through an amplifier 113 and a flip-flop 115 which provides a balanced or symmetrical waveform as described previously. The counting chain is provided with a plurality of interlocking digital feedback paths, designated 117-121, each of which includes a respective gate 123-128 for permitting the path to be selectively opened or closed. The particular feedback paths are selected so that the change in the ultimate output frequency produced by changing the state of each gate has a desired musical significance. For example, the various gates are preferably arranged to produce changes in frequency of an octave (2:1), a 5th (3:1), a 4th (4:3), a 2nd (about 64:57) and a 3rd (about 63:50). The particular interconnections necessary to achieve these ratios with particular, commercially available, integrated circuit logic systems will be apparent to those skilled in the art. In this embodiment, it can thus be seen that the various tones or frequencies are provided by selective frequency division or counting, rather than by repetitive addition or accumulation of a number related to the desired frequency as in the FIG. 1 embodiment.

For note sequencing, the slow clock oscillator 101 drives a counter comprising a plurality of binary stages 141-144. The last stage (144) provides the clock or shift input to an eight-stage shift register 145. Spill over from the shift register 145 triggers a commutating flip-flop 146 and the output signal from the flip-flop is in turn fed back to the input terminal of the shift register to provide a feedback mode of operation. If desired, this feedback function can be further modified by data taken from various stages in the shift register, as in the embodiment of FIG. 1, so as to provide further varieties of long-term periodic sequences.

The tone shifting gates 123-128 are controlled as preselectable logical functions of the various digital signals obtained from the counting stages 141-144 and from the various stages or points of the shift register 145. As will be understood, myriad combinations of these signals can be devised and will generate corresponding sequences of notes. One particular set of selection switches is illustrated in the embodiment of FIG. 1 but, as will be understood, various types of switching and/or logic gating may be employed. Thus, in FIG. 6 this function of combining various control signals is designated generally as permutative switching circuitry 160. As is also understood, this switching can be employed to apply feedback to the various counting stages 141-144, which feedback varies as a logical function of the signals present in the counting stages 141-144 and the bits of information circulating through the shift register 145. As will be understood by those skilled in the art, the use of various combinations of feedback signals will cause the counting stages 141-144 and the shift register 145 to generate a great variety of periodic sequences, typically having a very long repetition period. Thus, the note sequences generated by the synthesis portion of this circuit can also be widely varied as were the sequences provided by the FIG. 1 embodiment.

While the embodiments described above are electronic in nature and are adapted for construction using available digital logic modules or using large scale integration technique, it should be understood that other embodiments can be constructed using mechanical or fluidic logic elements. Individual mechanical equivalents for the various logic elements used in this invention are known in the art and such elements can be assembled into a system in accordance with the present invention.

In view of the foregoing, it may be seen that several objects of the present invention are achieved and other advantageous results have been attained.

As various changes could be made in the above constructions without departing from the scope of the invention, it should be understood that all matter contained in the above description or shown in the accompanying drawings shall be interpreted as illustrative and not in a limiting sense.

We claim:

1. Apparatus for making music, said apparatus comprising: tone generating means operating to provide a variety of musical notes in response to respective predetermined combinations of control signals applied thereto; a register which comprises means for holding a plurality of bits of digital information in a given order, said held information being changeable according to a predetermined pattern in response to input signals applied to said register; means for reading digital information held in said register at a plurality of selected points in said register; means for applying to said register at least a first input signal which is obtained according to a preselectable code from bits of information obtained from said plurality of points; means for applying to said register a second input signal which varies according to a predetermined periodic function thereby to cause the information held in said register to periodically change in a predetermined sequence; and means for applying to said tone generating means control signals which vary as respective preselectable logical functions of the information held in said register thereby to cause said tone generating means to produce a sequence of notes, the pattern of which is a function of the changing information held in said register.
2. Apparatus as set forth in claim 1 wherein said register is a shift register.
3. Apparatus as set forth in claim 2 wherein said means for applying said one input signal includes a plurality of selector switches, each of which selects a signal from one of a predetermined plurality of stages of said shift register and logic gate means for combining the selected signals according to a predetermined binary logic function thereby to generate said first input signal.
4. Apparatus as set forth in claim 3 wherein said logic gate means comprises an EXCLUSIVE OR gate.
5. Apparatus as set forth in claim 3 wherein said means for applying a second input signal comprises an oscillator connected to said shift register to cause information held in said register to be shifted at a repetition rate which is related to the frequency of operation of said oscillator.
6. Apparatus as set forth in claim 1 wherein said register comprises a multistage counter and means for selectively providing digital feedback to selectively vary the pattern of states generated by said counter.
7. Apparatus as set forth in claim 6 wherein said means for applying a second input signal comprises an oscillator connected to said counter for causing said counter to be incremented through successive states at a rate which is related to the frequency of operation of said oscillator.
8. Apparatus as set forth in claim 1 wherein said tone generating means comprises means for selectively generating a plurality of note signals representing respective musical notes and gate means for passing a selected one of said note signals in response to said control signals.
9. Apparatus as set forth in claim 8 further including a plurality of selector switches each of which selects a signal from one of a plurality of predetermined stages of said register, said selected signals being applied to said gate means as said control signals.
10. Apparatus as set forth in claim 1 wherein said tone generating means comprises gate means operable to selectively change a note being generated and also comprises a plurality of selector switches each of which selects a signal from one of a plurality of predetermined stages in said register, said selected signals being applied to control said gate means.
11. Apparatus as set forth in claim 1 wherein said tone generating means comprises:
  - a digital accumulator;
  - means for generating a plurality of digital signals, one for each note to be generated, representing respective preselected binary numbers, the values of said binary numbers being in proportion to the note frequencies;

- means for selecting one of said digital signals and applying the selected signal to said accumulator;
- means for driving said digital accumulator to repetitively and periodically add the binary number represented by said selected digital signal to the sum number held in said accumulator; and
- means for generating an output signal which represents a selected carry bit in said sum number, whereby the base frequency of said output signal is proportional to the number represented by the selected digital signal and thus also to the note frequency determined by said control signals.
12. Apparatus as set forth in claim 1 wherein said tone generating means comprises an oscillator and a multistage frequency dividing counter driven by said oscillator, said counter having a plurality of digital feedback paths, each of said paths having gate means for selectively rendering the respective path inoperative thereby to change the output frequency of the counter by a predetermined factor, said control signals being applied to said gate means to vary the note being generated as a function of the information held in said register.
13. Apparatus for generating a plurality of tone signals having a predetermined scalar frequency relationship, said apparatus comprising:
  - means for generating a plurality of digital signals, one for each tone signal, representing respective preselected binary numbers, the values of said binary numbers being related in the same scalar manner as said tone signal frequencies;
  - a digital accumulator;
  - means for selecting one of said digital signals and applying the selected signal to said accumulator;
  - means for driving said digital accumulator to repetitively and periodically add the binary number represented by said selected digital signal to the sum number held in said accumulator; and
  - means for generating an output signal which represents a selected carry bit in said sum number, whereby the base frequency of said output signal is proportional to the number represented by the selected digital signal and thus also to a respective tone frequency.
14. Apparatus as set forth in claim 13 wherein said accumulator operates in a serial mode and said digital signals are generated in a corresponding serial format.
15. Apparatus as set forth in claim 14 wherein said means for driving said accumulator comprises an oscillator providing a clock signal at a preselected frequency and wherein said clock signal is applied also to said digital signal generating means for timing said serial format, whereby the pitch of said tone signals can be adjusted by varying the frequency of said oscillator while the relationship between the various tone frequencies is maintained.
16. Apparatus for making music, said apparatus comprising:
  - a shift register for holding a plurality of bits of digital information in a given order;
  - means for shifting data held in said register at a preselectable repetition rate;
  - means for reading digital information held in said register at a plurality of selected points in said register;
  - a first pair of selector switches each of which selects one signal from a predetermined plurality of stages of said shift register;
  - logic gate means for combining the signals selected by said first pair of switches and applying to said shift register an input signal which is a predetermined logical function of the signals selected by said first pair of switches;
  - means for generating a plurality of digital note signals representing respective preselected binary numbers, there being one digital signal for each of a plurality of notes to be generated, the values of said binary numbers being in proportion to respective predetermined musical note frequencies;
  - a digital accumulator;



selection gate means for selecting one of said digital note signals in accordance with a plurality of control signals applied to said selection gate means, the selected digital note signal being applied to said accumulator;

a second pair of selector switches each of which selects one signal from a plurality of stages of said shift register, the signals selected by said second pair of switches being applied to said gate means as said control signals;

means for driving said digital accumulator to repetitively and periodically add the binary number represented by said selected digital note signal to the sum number held in said accumulator; and

means for generating an output signal which represents a selected carry bit in said sum number,

whereby the base frequency of said output signal at any given time is proportional to the number represented by the respective selected digital note signal and thus also to the respective note frequency and whereby the frequency

of said output signal changes in a pattern determined by the setting of said selector switches.

17. Apparatus as set forth in claim 16 including means for counting selected events in the pattern of notes generated and for periodically modifying one of said control signals after a predetermined count thereby to provide a grace note.

18. Apparatus as set forth in claim 16 including means for counting selected events in the pattern of notes generated and for periodically, in response to the count, changing the repetition rate at which data is shifted in said register thereby to provide a change in tempo.

19. Apparatus as set forth in claim 16 including means for counting selected events in the pattern of notes generated and for periodically, in response to the count, changing the sample bit of the sum number in the accumulator thereby to change the pitch of the note sequence being generated by one octave.

20

25

30

35

40

45

50

55

60

65

70

75