

P. T. LINDHOLM.
ADDING MACHINE.

No. 343,770.

Patented June 15, 1886.

Fig. 1.

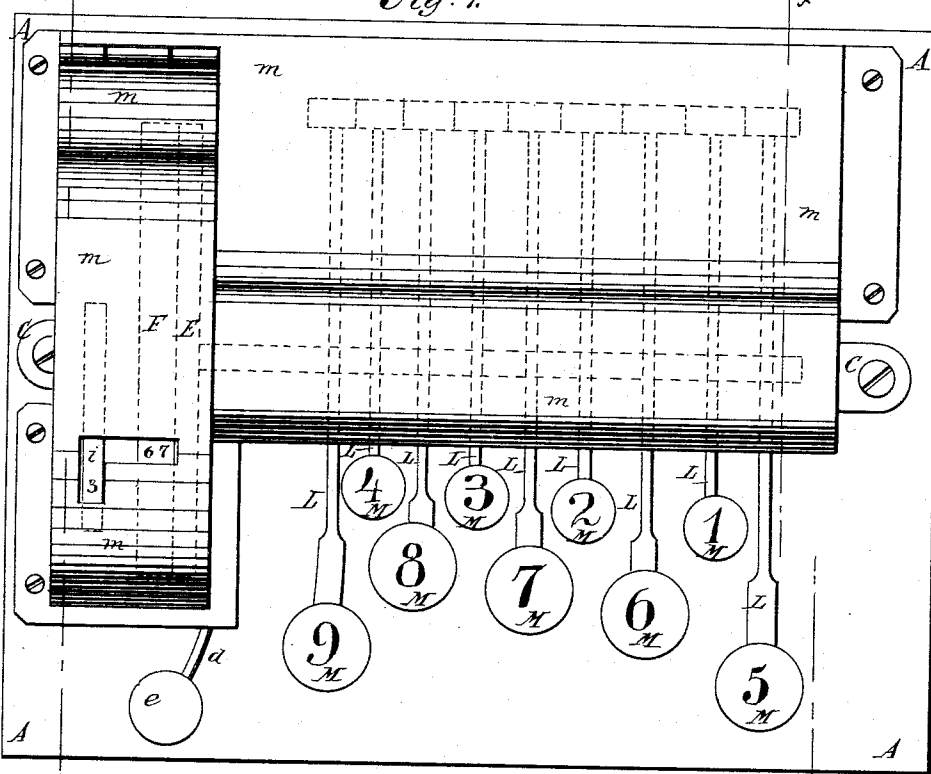
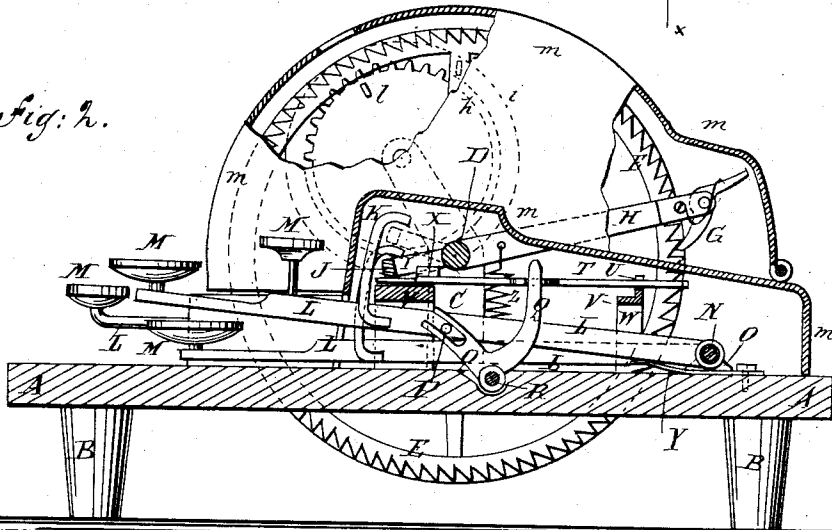

Fig. 2.



WITNESSES:

C. A. Nida
C. Hedqvist

INVENTOR:

P. T. Lindholm
BY *Munn & Co*
ATTORNEYS.

P. T. LINDHOLM.
ADDING MACHINE.

No. 343,770.

Patented June 15, 1886.

Fig. 3.

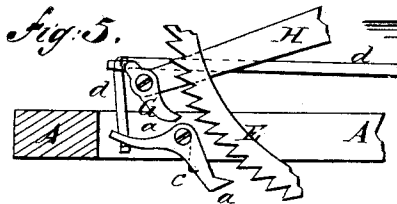
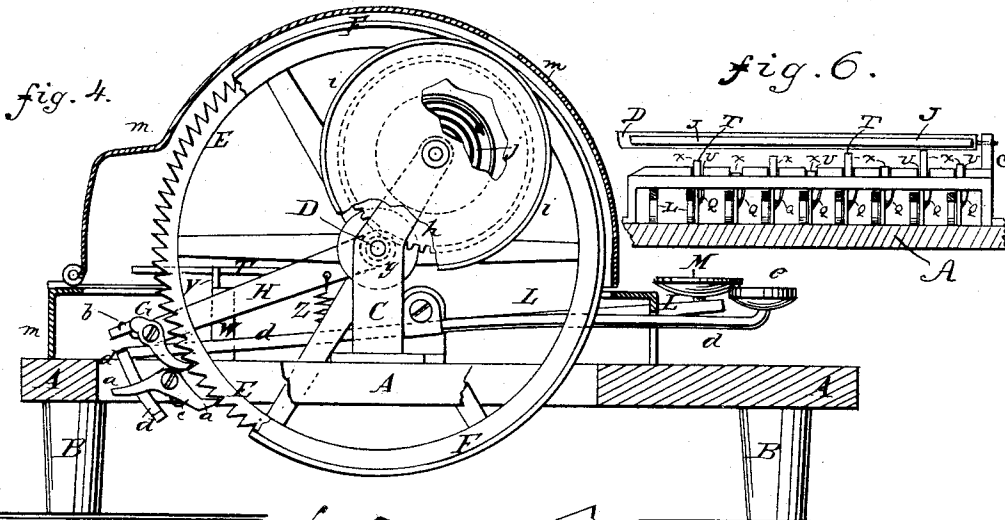
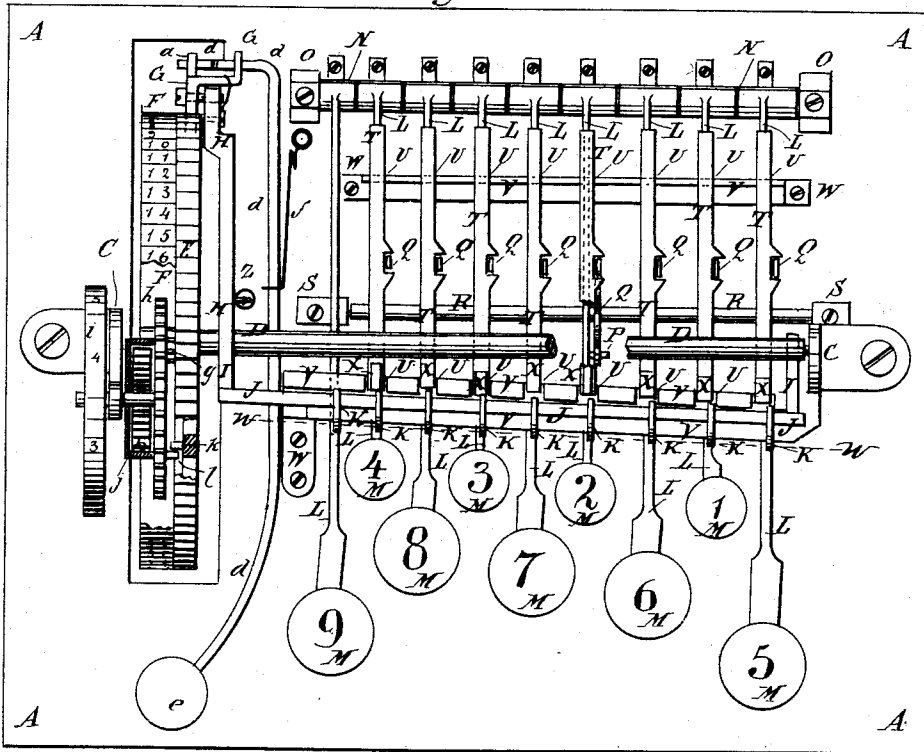

WITNESSES:

Chas. Nida
C. Sedgwick

INVENTOR:

P. T. Lindholm

BY *Munn & Co*

ATTORNEYS.

UNITED STATES PATENT OFFICE.

PETER T. LINDHOLM, OF LINDSBORG, KANSAS.

ADDING-MACHINE.

SPECIFICATION forming part of Letters Patent No. 343,770, dated June 15, 1886.

Application filed November 10, 1885. Serial No. 182,345. (No model.)

To all whom it may concern:

Be it known that I, PETER T. LINDHOLM, of Lindsborg, in the county of McPherson and State of Kansas, have invented a new and
5 useful Improvement in Adding-Machines, of which the following is a full, clear, and exact description.

Reference is to be had to the accompanying drawings, forming a part of this specification, in which similar letters of reference indicate
10 corresponding parts in all the figures.

Figure 1 is a plan view of one of my improved adding-machines. Fig. 2 is a sectional side elevation of the same, taken through the line
15 *xx*, Fig. 1, and parts being broken away. Fig. 3 is a plan view of the same, the case being removed and parts being broken away. Fig. 4 is a side elevation of the same, partly in section
20 through the line *yy*, Fig. 1, and parts being broken away. Fig. 5 is a part of the same section enlarged. Fig. 6 is a section on line *ww* of Fig. 3.

The object of this invention is to provide adding-machines constructed in such a manner
25 as to be convenient in use and reliable in operation.

The invention consists in the construction and combination of various parts of the adding-machine, as will be hereinafter fully described.
30

A represents the bed-plate of the machine, which is supported upon legs B, of such a length as to raise the machine to a convenient height.

35 To the middle side parts of the bed-plate A are attached bearings C, in which are journaled the ends of a shaft, D.

Upon the shaft D, near one end, is placed loosely a ratchet-wheel, E, the lower part of
40 which enters a slot in the bed-plate A, to allow the said wheel to be made as large as possible. The ratchet-wheel E is made with a hundred teeth upon the face or side of its rim, and upon its rim is formed, or to it is rigidly attached, an
45 annular flange, F, upon which are formed numerals from one to a hundred in their natural order. The ratchet-wheel E is turned forward by a pawl, G, pivoted to an arm, H, rigidly
50 attached to the shaft D, and projecting to the rearward.

To the shaft D are rigidly attached two short forwardly-projecting arms, I, one of which may

be a forward projection of the arm H. To the outer ends of the arms I is rigidly attached a bar, J, with which engage hooks K, the shanks
55 of which are attached to levers L, provided at their forward ends with finger-keys or knobs M. The rear ends of the levers L are pivoted to a rod, N, secured to supports O, attached to the rear part of the bed-plate A. 60

To the sides of the middle parts of the levers L are attached pins P, which enter slots in the lower arms of the elbow-levers Q. The elbow-levers Q are pivoted at their angles to a rod, R, secured to supports S, attached to the bed-plate A. The upper arms of the elbow-levers Q rest in recesses in the side edges of the bars T, which rest and slide in recesses U in the upper sides of the bars V, secured to supports W, attached to the bed-plate A, so that the
65 said slides T will be moved forward and back by the up-and-down movement of the levers L. 70

Upon the upper sides of the forward ends of the slides T are formed projections X, which, as the said slides are moved forward, come beneath the bar J and limit its downward movement, and consequently the upward movement of the arm H and pawl G. The projections X are graduated in height, so that as each projection X comes beneath the bar J it will
75 allow the said bar to descend only so far as will allow the pawl G to pass up over so many teeth of the ratchet-wheel E as are indicated by the numeral appropriated to the key of the lever connected with the bar carrying the said
80 projection. The key-levers L are raised after each depression by springs Y, placed beneath them near their rear ends. The arm H, after being raised; is drawn down by a spiral spring, Z, or other suitable spring connected with the
85 said arm and with the bed-plate A, causing the pawl G to turn the ratchet-wheel E forward. The ratchet-wheel E is held from being turned back by the friction of the pawl G while being raised by a pawl, *a*, pivoted to
90 the bed-plate A or other suitable support, and which engages with the teeth of the said ratchet-wheel. The engaging ends of the pawls G *a* are held against the teeth of the ratchet-wheel E by springs *b c*, pressing against the
95 said pawls and attached to their supports. The rear ends of the pawls G *a* project above shoulders formed upon the rear end of the lever *d*, pivoted to a support attached to the

bed-plate A and provided with a key, *e*, at its forward end, for convenience in operating it. The shoulders of the lever *d* are so arranged as to raise the pawl G a little in advance of the pawl *a*. The rear end of the lever *d* is lowered, after being raised, by a spring, *f*, connected with its rear part and attached to the bed-plate A.

To the outer end of the hub of the ratchet-wheel E is attached a small pinion-wheel, *g*, into the teeth of which mesh the teeth of the gear-wheel *h*, the journal of which revolves in an upward extension of the bearing C. With the gear-wheel *h* or with its journal is connected a flange or rim, *i*, upon which are formed equidistant division-marks numbered 1, 2, 3, and so on, as many division-marks being used as the teeth of the gear-wheel *h* are multiples of the teeth of the pinion-wheel *g*, so that the flange *i* will indicate the number of revolutions of the ratchet-wheel E, and consequently the number of hundreds in the sum. The gear-wheel *h* should be made as large as possible, while keeping the part of the flange *i* displayed flush with the displayed part of the flange E, so that the hundreds can be readily read in connection with the corresponding tens and units.

With the journal of the gear-wheel *h* is connected the inner end of a coiled spring, *j*, the outer end of which is connected with the bearing C or with a drum rigidly attached to the said bearing. The spring *j* is so arranged as to be coiled up by the forward revolution of the gear-wheel *h*, and should have sufficient strength to turn the ratchet-wheel E and gear-wheel *h* back to the zero-points, when the pawls G *a* are raised out of contact with the said ratchet-wheel.

To the adjacent sides of the ratchet-wheel E and gear-wheel *h* are attached pins *k l*, in such positions as to come in contact when the said wheels are both at the zero-point, but which will pass each other when the said wheels are in all other positions, so that the said wheels E *h* will always be stopped at the zero-point when turned back by the action of the spring *j*.

The mechanism of the machine is covered by a casing, *m*, leaving exposed the forward ends of the levers L *d* and the keys M *e*. The part of the casing *m* over the zero-marks of the flanges F *i* of the wheels E *h* have apertures formed in them, to display the said parts of the said flanges, so that the sum can be readily read.

In using the machine, the keys M, representing the figures to be added, are successively depressed, and the sum of the column of figures is read from the flanges F *i*, through the apertures in the casing *m*. When the sum has been noted down on paper by the operator, the key *e* is depressed, the wheels return to the zero-point, and the machine is ready for adding another column of figures.

The ratchet-wheel E is kept from going too far when it is turned forward by the down-

ward movement of the pawl G by the forward end of the said pawl G coming in contact with the upper part of the holding-pawl *a*, and being thus held against the teeth of the said ratchet-wheel E, so that the said ratchet-wheel will always be stopped in its forward movement at exactly the right spot, and held from rebounding.

Having thus fully described my invention, I claim as new and desire to secure by Letters Patent—

1. In an adding-machine, the combination, with the bed-plate A, the shaft D, and the loosely-revolving ratchet-wheel E, having index-flange F, of the arm H, attached to the said shaft, the pawl G, pivoted to the said arm, the arms I, attached to the said shaft, the bar J, connecting the said arms, the spring-pressed key-levers L, having hooks K, engaging with the connecting-bar, the elbow-levers Q, connected with the said key-levers, the slides T, connected with the elbow-levers, and having graduated projections X, the recessed bars V, carrying the said slides, and the spring Z, connected with the pawl-carrying arm, substantially as herein shown and described, whereby the said ratchet-wheel will be turned forward through fixed spaces by operating the said key-levers, as set forth.

2. In an adding-machine, the combination, with the shaft D and the loosely-revolving ratchet-wheel E, of the arm H, pawl G on the end of the said arm, spring Z, the arms I, the bar J, connected to said arms I, and the key-levers L, provided with hooks K, engaging said bar J, substantially as herein shown and described.

3. In an adding-machine, the combination, with the loosely-revolving ratchet-wheel E, the key-levers L, and intermediate mechanism for operating the ratchet-wheel from the key-levers, of slides having graduated projections, and elbow-levers engaging the said key-levers and slides, substantially as and for the purpose set forth.

4. In an adding-machine, the combination, with the shaft D, the loosely-revolving ratchet-wheel E, the spring-pressed arm H, the pawl G, the arms I, the bar J, and the key-levers L, provided with hooks K, of the slides T, having projections X, the rock-shaft R, and the elbow-levers Q, engaging said slides and key-levers, substantially as herein shown and described.

5. In an adding-machine, the combination, with the shaft D, the loosely-revolving ratchet-wheel E, having index-flange F, the key-levers L, and intermediate mechanism for operating the ratchet-wheel from the said key-levers, of the pinion *g*, the gear-wheel *h*, the spring *j*, and the stop-pins *k l* on the said ratchet-wheel E, and gear-wheel *h*, substantially as herein shown and described.

PETER T. LINDHOLM.

Witnesses:

G. E. EBERHARDT,
H. A. OLSTON.