

C. G. SPALDING.
Adding-Machines.

No. 146,407.

Patented Jan. 13, 1874.

Fig. 1

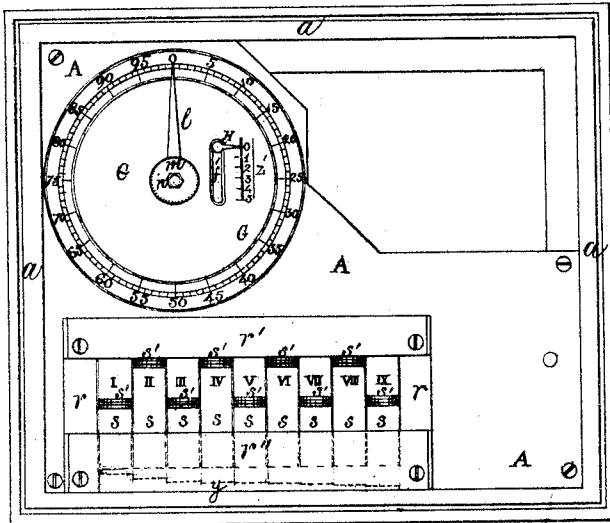

Fig. 3

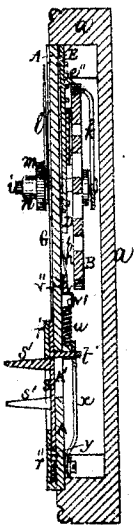
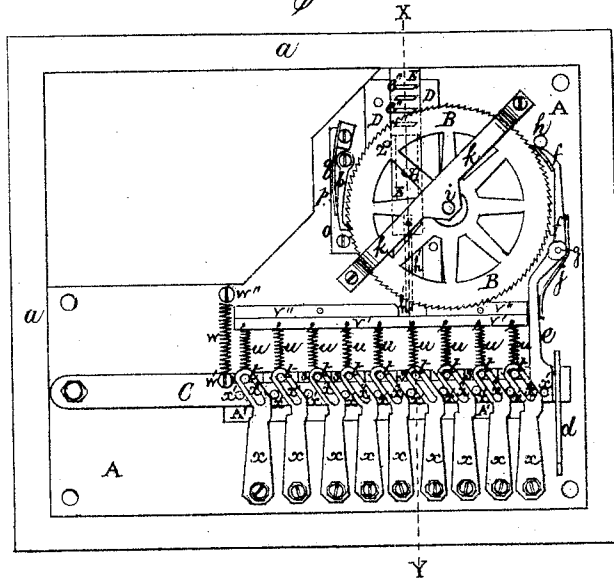

Fig. 2



Witnesses
 Sam^l M. Barton.
 Jesse F. Wheeler.

Inventor
 Cyrus G. Spalding
 by his atty
 Howell Dwight.

UNITED STATES PATENT OFFICE

CYRUS G. SPALDING, OF BOSTON, MASSACHUSETTS.

IMPROVEMENT IN ADDING-MACHINES.

Specification forming part of Letters Patent No. **146,407**, dated January 13, 1874; application filed June 7, 1873.

To all whom it may concern:

Be it known that I, CYRUS G. SPALDING, of Boston, in the county of Suffolk and State of Massachusetts, have invented certain Improvements in Adding-Machines, of which the following is a specification:

Figure 1 of the accompanying drawing is a front view, and Fig. 2 is a rear view, of the interior of my improved adding-machine. Fig. 3 is a vertical transverse section taken in line X Y of the same.

The present invention relates to certain new and useful improvements in machines for adding or registering numbers; and has for its principal object the production of a machine that shall be simple in construction, economical in cost, and effective in its operation. My improvements consist, mainly, in a series of mechanical devices, arranged and operated, as will be more fully described hereinafter, so that a pivoted lever, operated at different points by digit-keys, shall cause a ratchet to take up a number of teeth of a rotating indicator-wheel, and revolve, over a suitably figured and spaced dial, an index-hand a certain number of points, according to the key manipulated. These improvements also consist of a sliding rack, arranged and operated, as will be duly described, so as to be lowered one point, at each revolution of a wheel, by the contact and release of a pin connected with the said wheel with and from the teeth or bars of the rack. And, finally, these improvements consist in several minor mechanical devices, the arrangement and functions of which will be fully explained in due course.

In the drawings, *a* represents a case, in which is located a frame, *A*, formed at the lower portion with a longitudinal slot, *A'*. At one end of the lower portion of the frame *A*, at the rear, is pivoted one end of a longitudinal lever, *C*, the other end of which lever has an up-and-down play in a slotted vertical standard, *d*, and is connected with the bottom of a vertical lever-arm, *e*, bent and bifurcated at the top to receive and allow the movement of a pawl, *f*, the bottom of whose arm turns on a pivot, *g*, supported in the top portion of the lever-arm *e*. The top of the pawl *f* is bent inward, and beveled on the edge to mesh with the teeth of an indicator ratchet-wheel, *B*, and is formed

on the top so as to abut against, and be held in position by, a stem, *h*. A spring, *j*, is attached to the back of the lower portion of the ratchet *f*, and extends downward so as to impinge at the bottom against the back of the arm *e*, for the purpose of throwing the ratchet *f* in between the teeth of the wheel *B*, which wheel *B* is located in the upper portion of the frame *A*, at the rear, and has an axle, *i*, supported by, and turning in, a bridge, *k*, and in the frame *A*, through the latter of which it extends, and is provided, on the outside, with an index-hand, *l*, a milled thumb-disk, *m*, and held by a screw-nut, *n*, turning on the end of the axle *i*, and bearing against the outside of the disk *m*. Pivoted to a plate, *o*, or otherwise connected with the frame *A* on the side of the wheel *B* opposite to that of the ratchet *f*, is a pawl, *p*, the toothed end of which engages with the teeth of the wheel *B*, the said pawl being regulated in its action by a spring, *q*, bearing against its back, and attached to the top of the plate *o*, or to the frame *A*. Or any other mechanical device, or arrangement of devices, that may be preferred, may be applied to the wheel *B* to hold it, and prevent its slipping back from the desired point. On the lower portion of the front of the frame *A* is a frame consisting of two vertical side plates, *r*, and a top plate, *r'*, and a bottom plate, *r''*. The top plate *r'* and bottom plate *r''* extend longitudinally, and are screwed, or otherwise attached, to the face of the vertical plates and frame *A*. Or the frame may be otherwise arranged to receive, hold, and allow the up-and-down movement of a series of nine, or any desired number, of keys, *s*, arranged vertically parallel with and adjoining each other, each key being formed with a front horizontal projecting digit-piece, *s'*, alternating one above another, as shown in Figs. 1 and 3. Projecting horizontally from the rear of each key *s*, just above the top of the lever *C*, is a pin, *t*, to which is attached the bottom of a spiral spring, *u*, or its equivalent, whose top is connected with the downward-extending flange *v'* of a projecting longitudinal horizontal bar, *v*, that has an upper flange, *v''*, attached to the rear of the frame *A*. Or the springs *u* may be connected with the frame *A* by any other method that may be preferred. Connected with the top of the lever

C by a screw, w' , or otherwise held toward its pivoted end, or in any other desired position, is one end of a spiral spring, w , which is held at the top by a screw, w'' , or otherwise secured to the frame A. Or any other arrangement for holding and returning the lever C to its original position that may be preferred may be used in place of the spring w . To the lower portion of the rear of the frame A are pivoted, at the bottom, a series of vertical stop-bars, x , corresponding in number to the keys used. Each stop-bar x is notched in on one side, and inclined upward at the top to receive and arrest a stop-pin, x' , and limit the downward motion of the lever C, which is provided with as many stop-pins as there are keys, the said pins x' being located at equal intervals on its rear, from which they project horizontally, each pin x' being situated on the lever C, a little to one side of the key-pins t . Each stop-bar x is formed in its top inclined portion with an inclined slot, x'' , in which travels, when the key s is brought down, the slide-pin t , so as to throw the stop-bar x to one side, and cause it to abut against and hold the lever stop-pin x' . At the bottom of the keys s , between the bottom plate v'' and the face of the frame A, is secured a longitudinal gage-piece, y , which is, at the width of each key s , stepped downward at different levels, as shown by the dotted lines, Fig. 1, so as to check and regulate the downward movement of the keys s . Attached to the upper portion of the frame A, at the rear, on one side of the center of the indicator-wheel B, are vertical ways D, beveled or otherwise formed on the inner edges to receive and allow the up-and-down travel of a sliding indicator-rack, E, formed on the rear with horizontal teeth or bars e'' , and having an index, H, projecting from its front, that is arranged to operate up and down in a vertical slot, f' , formed in the plate A, and travel vertically over the face of a dial, G, connected with the front of the frame A, and suitably lined and figured to correspond to the number of teeth or bars e'' on the rack E, the number of the teeth or bars e'' being equal to the number of hundreds that it is desired to compute. The rack E is held in position by means of a friction-spring, h' , attached to its bottom, and bearing against the rear of the frame A. The dial G is lined with a circular border suitably spaced and figured, as shown in Fig. 1. The indicator-rack E is lowered one bar or tooth at every revolution of the indicator-wheel B, by the contact and release of a pin, z , projecting from the face of the said wheel, with and from the bar or tooth of the said rack. The ends of the teeth or bars e'' are oppositely beveled to facilitate the connection and release of the pin z with the teeth.

The operation of my invention is as follows: The index l is set to the zero-point on the dial G by pressing on one of the digit-pieces s' , which lowers the key s connected with it, and operates the lever C, so as to drop the pawl f

and allow the indicator-wheel B, and, consequently, the index l , connected with its axle i , to be revolved by the operator turning the thumb-disk m to the right. The index is then pushed up to the top or zero-point of the vertical register z' . When it is desired to add any number, the digit-piece s' , corresponding to the number required, is pressed down, thereby lowering its key s , and causing its key-pin t to bear upon the top of the lever C, which is thus borne down a greater or less distance, according to the nearness of the pin operated to the fulcrum of the lever, thereby lowering and throwing outward the arm e and ratchet f , and bringing down the latter a certain number of teeth on the indicator-wheel B, according to the position of the key manipulated, the pawl f being prevented from slipping beyond the desired tooth by the action of the slotted pivoted stop-bar x , which, as the lever is lowered, is thrown one side by the key-pin t bearing on the side of the inclined slot x'' , until the lever stop-pin x' abuts against and is held by the notched portion of the stop-bar x . When the key s has been thus brought down, the pressure on the digit-piece s' is instantly released, and the lever C raised to its original position by the action of the spring w and the auxiliary springs u , which raise and hold the keys s , thus raising the lever arm e and pawl f , and pressing the latter against the tooth under which it fell by the lowering of the lever C, and revolving the wheel B the distance of the number of the teeth dropped by the previous operation, and carrying the index l around the dial G a number of points identical with the number of teeth taken up by the ratchet f , and corresponding to the number of the key operated upon, each key, in the present instance, being numbered from one to nine, inclusive, to correspond with the units to be added. The wheel B is held at the desired point, and prevented from slipping back, by means of the pawl p , which is operated by the spring q , so as to be thrown into gear with the wheel B at the passage of every tooth; and the lever C is prevented from rising beyond its desired position by the contact of the key-pin t with the top of the slot A' , and the contact of the end of the lever with the top of the slotted guide-standard d .

By operating the several keys s , as above described, the figures up to one hundred may be added and indicated by the index l on the dial. When a hundred has been registered, the index l will again be at the zero-point, when the revolution of the wheel B at this point will cause the pin z to come in contact with and press down the lower tooth of the sliding rack E, which is consequently lowered and the pin released, and the index H carried down one point on the vertical register, thus indicating that one hundred has been computed. At the next revolution of the wheel B the pin z operates in like manner, and the index H is lowered to the second point, thus noting the second hundred, and so on, a hundred being

noted at each revolution of the wheel B; and as many hundreds may be indicated as there are teeth on the rack E.

It will be evident that, if desired, additional keys may be applied to the same lever for registering higher numbers than nine.

Having thus fully described my improvements, what I claim as my invention, and desire to have secured to me by Letters Patent, is—

The arrangement, in an adding-machine, of the following instrumentalities, substantially

as described, to wit: Keys *s* with digit-pieces *s'* and pins *t*, pivoted stop-bars *x* formed with an inclined slot, *x''*, and notched to receive and arrest stop-pins *x'*.

In testimony whereof I have signed my name to this specification in the presence of two subscribing witnesses.

CYRUS G. SPALDING.

Witnesses:

CARROLL D. WRIGHT,
SAML. M. BARTON.