

Dec. 31, 1935.

G. TAUSCHEK

2,026,329

READING MACHINE

Filed May 27, 1929

*Fig. 1*

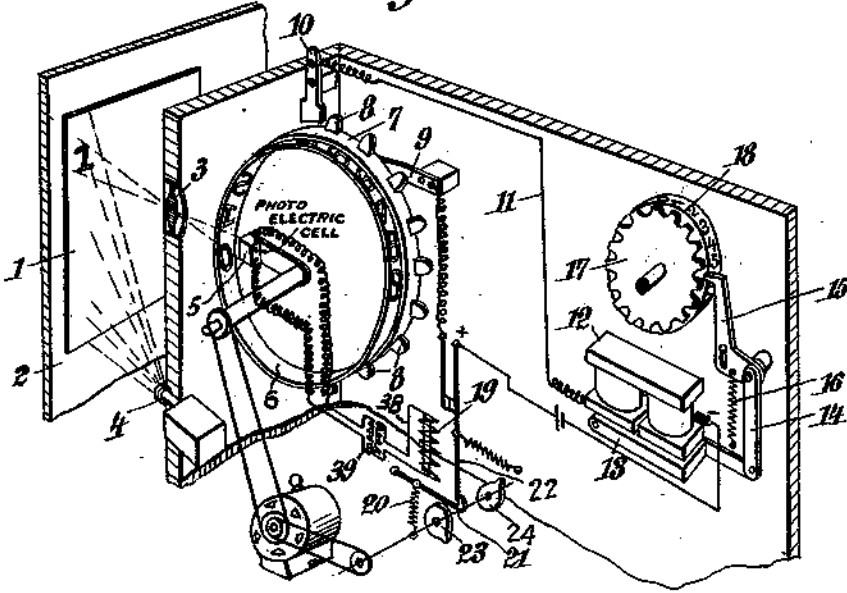

*Fig. 2.*



INVENTOR:  
*Gustav Tauschek*  
BY: *Marks & Clark, Attys.*

# UNITED STATES PATENT OFFICE

2,026,329

## READING MACHINE

Gustav Tauschek, Vienna, Austria

Application May 27, 1929, Serial No. 366,466  
In Austria May 30, 1928

26 Claims. (Cl. 250—41.5)

This invention relates to improvements in machines which are provided with arrangements adapted to create ray-images, particularly light ray images, of character or indications so as to cause by a comparing mechanism certain actions to be instituted thereby effecting the reading of such characters or indications, and thus replace reading by a person.

In order to attain this object the arrangement according to the present invention is provided with cells, in which the electric conductivity is varied by radiation, and with comparison devices which on the arrival of certain rays influencing the cells direct or control the corresponding operations.

The invention can be utilized for controlling any desired machine, however it will be found very useful in connection with office-machines, which heretofore could be operated only by persons who were able to read. Further the machine may be used for testing and counting securities, bank-notes and so forth and for controlling automats and the like.

One of the modes of carrying out the present invention is illustrated diagrammatically by way of example on the accompanying sheet of drawing in which:—

Fig. 1 shows a perspective view of one construction, and

Fig. 2 is a detail view.

The embodiment shown in Fig. 1 serves for controlling the counting mechanism of a calculating machine. The record or sheet 1, provided with characters or the numerals for calculation, is placed on a base or carrier 2 in such a manner, that the number to be read is disposed opposite the lens 3, the record being illuminated by a strong source of light 4. On the other side of the lens 3 a suitable distance away, is arranged a photo-electric cell 5, in front of which rotates a movable device such as a wheel 6 constituting a portion of a comparison device, provided with stencil-recesses corresponding to the numerals 0 to 9. The stencil-recesses are of such a size and are shaped according to the numerals and are distanced in such a manner from the lens 3 that for instance the image of the numeral 1 exactly coincides with the stencil-recess as soon as the latter is disposed at the corresponding place. A contact wheel 7, provided with nine contact-knives 8 and supplied with current by way of a brush 9, is connected with the wheel 6. A contact-spring 10 is arranged opposite the contact wheel in such a manner, that the knives 8 establish electric connection

during the rotation of the said contact wheel. A wire of an operating circuit 11 leads from the contact spring 10 to a control-magnet 12 which on being charged with current attracts the armature 13 and by way of a link 14 forces a pawl 15 against the action of a spring 16 into a toothed feed-wheel 17 and feeds forward the latter for the extent of a tooth. A number-wheel or number representing or manifesting wheel 18 is connected with the feed-wheel 17 and accordingly is fed forward also the extent of one place. In the circuit of the photo-electric cell 5 are included a low frequency transformer 19 and a relay-magnet 19, which controls the current supply of the brush 9. During the rotation of the wheel 6, rays of light will periodically pass to the cell 5 by way of the successive stencil-recesses of the wheel 6. The cell 5 is subjected to full light if a blank place of the sheet 1 is disposed opposite the lens 3. However a numeral, for instance the numeral 1, does not completely fill the other stencil recesses as shown in Fig. 2 by way of example of the stencil-recess corresponding to the Figure 2. Therefore light of the white writing sheet still passes to the cell 5. However a minimum of illumination of the cell 5 will take place, as soon as the stencil-recess corresponding to the numeral to be read is disposed in front of the cell. The relay 19 in the control circuit 19 is adjusted to this illumination-minimum and allows the withdrawal of its armature 21 by means of the action of the spring 20. In this way the contact member 22 is released and thus the current-supply to the brush 9 is interrupted. Supposing the numeral 1 is to be read off, a contact-knife 8 would already have passed the contact-spring 10 at the time of the release of the relay-armature 21 and the figure-wheel 18 would have been fed forward for a unit by the generated current. The eight following contact-knives 8 would remain inoperative, because the current-supply to the brush 9 is interrupted. Supposing the numeral 3 is to be read off, three contact-knives would have become operative, the figure-wheel would have been fed forward for three units and so forth.

Two cams 23 and 24 return the parts 21 and 22 into the initial position after each revolution of the wheel 6.

The wheel 6 with the numerals or other characters thereon, constitutes a movable search member or character-bearing comparison device in the path of the rays of radiant energy. With said device move the wheel 7 and its contact knives or blades 8, said parts 7, 8 constituting

a control means adapted to open or close, at the contact spring 10, a gap in the operating circuit 11 which includes the work device or magnet 12 and also has another gap which is open or closed by the relay armature 21, the latter thus constituting another control means or control device for the operating circuit 11, which second control means is under the control of the photo-electric cell or other ray-sensitive device 5. The magnet 12 through its armature 13 and the parts connected therewith, controls manifesting means constituted by the wheel 18. This wheel moves in step with the wheel 7 as long as the character on the wheel 7 struck by the radiant energy does not correspond to the character on the record, but when the two characters do correspond, the manifesting wheel 18 stops owing to the interruption of the operating circuit at 21.

No separate source of current is required in the circuit of the photo-electric cell 5 when the latter is of the type that generates an electric current when exposed to light. When using a photo-electric cell of the other type, which does not generate a current but simply varies in resistance under the influence of variations of light, I would of course include a battery or other suitable source of current in said circuit.

I claim:—

1. A character comparing device comprising in combination a carrier for a character-bearing record, a ray sensitive device, a comparison device containing a series of different characters, means for directing rays of radiant energy upon said ray sensitive device by way of said record and of said comparison device, the latter being interposed between the record carrier and the ray sensitive device and being movable relatively to the said carrier to successively bring the several characters of said series into co-operative relation, through said rays, with the record character being examined at the time, and a circuit including said sensitive ray device and a work device, said work device being operated by said ray sensitive device when the characters of the record and of the comparison device agree to such an extent that the current in said circuit will assume a predetermined value adapted to cause an operation of said work device.

2. A character comparing device comprising in combination a ray sensitive device in the path of rays of radiant energy impinging on a character-record, a movable device bearing a series of characters each of which is adapted to be brought, by the movement of said movable device, into the path of said rays, to control their passage to said ray sensitive device and cause them to affect said ray sensitive device differently according as like or unlike characters are simultaneously in the path of said rays on the record and on said movable device respectively, manifesting means, control means movable with said movable device, an operative connection between the last-mentioned means and the manifesting means to control the latter, said operative connection including a control device, and an operative connection from the ray sensitive device to said control device, to cause the latter to be actuated only when the character on the record is substantially identical with that character on the movable device which at the time is in the path of the rays.

3. A character comparing device comprising in combination a ray sensitive device in the path of rays of radiant energy impinging on a character-record, a movable device bearing a series

of characters each of which is adapted to be brought, by the movement of said movable device, into the path of said rays, to control their passage to said ray sensitive device and cause them to affect said ray sensitive device differently according as like or unlike characters are simultaneously in the path of said rays on the record and on said movable device respectively, manifesting means, control means movable with said movable device, and an operating circuit controlling said manifesting means, said circuit being controlled both by said control means and by said ray sensitive device.

4. A character comparing device comprising in combination a ray sensitive device in the path of rays of radiant energy impinging on a character-record, a movable device bearing a series of characters each of which is adapted to be brought, by the movement of said movable device, into the path of said rays, to control their passage to said ray sensitive device and cause them to affect said ray sensitive device differently according as like or unlike characters are simultaneously in the path of said rays on the record and on said movable device respectively, manifesting means, control means movable with said movable device, and an operating circuit controlling said manifesting means, said circuit having two gaps, one controlled by said control means, and the other by said ray sensitive device.

5. A character comparing device comprising in combination a ray sensitive device in the path of rays of radiant energy impinging on a character-record, a movable device bearing a series of characters each of which is adapted to be brought, by the movement of said movable device, into the path of said rays, to control their passage to said ray sensitive device and cause them to affect said ray sensitive device differently according as like or unlike characters are simultaneously in the path of said rays on the record and on said movable device respectively, manifesting means bearing a series of characters corresponding to those on said movable device, control means movable with said movable device, an operative connection between the last-mentioned means and the manifesting means to control the latter, said operative connection including a control device, and an operative connection from the ray sensitive device to said control device, to cause the latter to be actuated only when the character on the record is substantially identical with that character on the movable device which at the time is in the path of the rays.

6. A character comparing device comprising in combination a ray sensitive device in the path of rays of radiant energy impinging on a character-record, a movable device bearing a series of characters each of which is adapted to be brought, by the movement of said movable device, into the path of said rays, to control their passage to said ray sensitive device and cause them to affect said ray sensitive device differently according as like or unlike characters are simultaneously in the path of said rays on the record and on said movable device respectively, movable manifesting means, and means whereby the ray sensitive device controls the movement of the manifesting means according as like or unlike characters on record and movable device are in the path of the rays at a particular time.

7. In a machine for reading an indication on a record, the combination of a ray sensitive device, a movable device having indications formed by portions permeable to rays and adapted to

influence rays of radiant energy projected, under the control of the indication on the record, upon the several permeable indications of the said movable device as such indications are brought successively into the path of said rays by the movement of said movable device, movable manifesting means, an operative connection for normally moving said manifesting means in response to movement of said movable device, and means, controlled by said ray sensitive device, for breaking said operative connection whenever the indication on the record is substantially identical with that indication on the movable device which at that time is in the path of the rays.

8. In a machine for reading an indication on a record, the combination of a ray sensitive device, a movable device having indications formed by portions permeable to rays and adapted to influence rays of radiant energy projected, under the control of the indication on the record, upon the several permeable indications of the said movable device as such indications are brought successively into the path of said rays by the movement of said movable device, manifesting means provided with a series of indications corresponding to those of the said movable device, actuating means controlled by the movement of said movable device, for successively bringing the individual indications of the manifesting means into indication condition as the corresponding indications of said movable device come into the path of said rays, and means, controlled by said ray sensitive device, for arresting the operation of said actuating means whenever the indication on the record is substantially identical with that indication on the movable device which at that time is in the path of the rays.

9. In a machine for reading an indication on a record, the combination of a ray sensitive device, a movable device having indications formed by portions permeable to rays and adapted to influence rays of radiant energy projected, under the control of the indication on the record, upon the several permeable indications of the said movable device as such indications are brought successively into the path of said rays by the movement of said movable device, movable manifesting means provided with a series of indications corresponding to those of the said movable device, an operative connection for normally moving said manifesting means in response to movement of said movable device, to bring the individual indications of the manifesting means into indicating position successively as the corresponding indications of said movable device come into the path of said rays, and means, controlled by said ray sensitive device, for breaking said operative connection whenever the indication on the record is substantially identical with that indication on the movable device which at that time is in the path of the rays.

10. In a reading machine the combination with a movable device having a series of ray penetrable apertures, of means for moving the device for exploring by rays of radiant energy an indication on a record by comparison with the series of ray penetrable apertures, a single ray sensitive device the intensity of the rays of radiant energy impinging on the ray sensitive device being reduced to a minimum when a ray penetrable aperture coincides with the indication on the record, a movable character manifesting means, and an operative connection for causing said manifesting means to move normally in step with said movable device, said operative

connection including a member controlled by the ray sensitive device, to cause such manifesting means to be affected differently according as like or unlike characters are simultaneously in the path of said rays on the record and on said movable device respectively.

11. In a reading machine, the combination of a ray sensitive device, a movable device adapted to control the projection of a character on a record upon the ray sensitive device by rays of radiant energy, means for manifesting a series of characters, means movable with the movable device, a controlling connection between said movable means and the manifesting means to control the latter, and means controlled by the ray sensitive device, for affecting the control exerted on the manifesting device by said movable means.

12. In a machine for reading characters on a record by means of rays of radiant energy, a ray sensitive device and an electric circuit therefor, a movable device having a series of characters, means for moving said device for successively comparing by rays of radiant energy impinging upon said ray sensitive device the series of characters with the character on the record, a movable character manifesting means, an operative connection between said movable device and said manifesting means, and a relay associated with the circuit of the ray sensitive device and responsive to a predetermined current value effected when substantial identity is secured between the character on the record and one of the characters of the movable device, and means controlled by said relay for affecting the movement of the character manifesting means to manifest the character on the record.

13. In a machine for reading a character on a record by means of rays of radiant energy, the combination with a ray sensitive device, of a movable device carrying a series of different characters, means for projecting rays of radiant energy upon the ray sensitive device under control of the character on the record, means for moving the character carrying device whereby each character modifies the rays projected to said ray sensitive device, a movable indicating device and means for normally moving it in step with said character carrying device, and electrical means under control of the ray sensitive device for affecting the extent of movement of the indicating device by its related moving means.

14. In a machine for reading a character on a record by means of rays of radiant energy, a ray sensitive device, means for projecting rays of radiant energy upon the ray sensitive device under control of the character on the record, a movable device carrying a series of characters, each modifying the rays of energy projected to the ray sensitive device, a character indicating device, means including an electrical device for normally moving said indicating device step by step during the movement of the movable device, and a relay including contacts for controlling the electrical device, said relay being controlled by the ray sensitive device and responsive only when the character on the record is substantially identical with that one of the characters of the movable device which at the time is in the path of said rays.

15. In a machine for reading a character on a record by means of rays of radiant energy, a minimum current responsive relay, a movable character manifesting device bearing a series of characters, a character comparing device carry-

ing a series of characters corresponding to those of said manifesting device, a device operatively connected with said relay and responsive to the rays of radiant energy which have impinged on a character of the character comparing device and on the character on the record to cause said relay to be responsive when said two characters are substantially identical, and means whereby said relay effects the extent of movement of the character manifesting device.

16. In a machine for reading a character on a record by means of rays of radiant energy, a relay including contacts, said relay being responsive to a current of minimum amperage, a device operatively connected with said relay and responsive to rays of radiant energy, a comparison device bearing a series of characters adapted to be brought successively into co-operative relation to rays which are in co-operative relation with the character on the record to develop a current of minimum amperage and cause said relay to be responsive when compared characters correspond with each other, a movable character indicating means, and actuating means controlled by said comparison device and including a series of contact blades and a spring coacting therewith for effecting a step by step movement of the character indicating means, the contacts of said relay being adapted to control said actuating means to affect the extent of movement of the indicating means.

17. In a machine for reading a character on a record, the combination of a character indicating device, means for moving said character indicating device, electro-magnetic means for controlling the operation of said moving means, a ray sensitive device for controlling said electro-magnetic means, a source of rays of radiant energy, and a comparison device bearing a plurality of characters adapted to be brought into the path of the rays of radiant energy impinging upon the ray sensitive device, to compare such characters successively with the character on the record, said ray sensitive device causing said electro-magnetic means to be inoperative when compared characters correspond with each other.

18. In a machine for reading an indication on a record, the combination of an indication manifesting device bearing a plurality of indications, means for actuating said indication manifesting device, means for controlling the operation of said actuating means, a ray sensitive device for controlling the controlling means, and a comparison device bearing a plurality of indications corresponding to those of said manifesting device and adapted to be brought into the path of rays of radiant energy impinging upon the ray sensitive device, to compare such indications successively with the indication on the record, said ray sensitive device causing said controlling means to be operative when compared indications correspond with each other.

19. In a reading machine, the combination of a ray sensitive device, a movable device adapted to control the projection of a number representing indication on a record upon said ray sensitive device, number indicating means movable to different extent according to the number to be indicated, actuating means including parts movable with the movable device to control the movement of the indicating means, and means for controlling the operation of said actuating means in accordance with the operation of the ray sensitive device.

20. In a machine of the class described con-

trolled by a record having a character thereon, a movable search member bearing a set of the different characters which may appear on such record, means for projecting by radiant energy upon said search member an image of the character appearing on the record, means for moving the search member to bring various characters thereof into successive relation to such image, and a device operated by such radiant energy when correspondence exists between a character on the search member and the character on the record.

21. In a machine of the class described controlled by a record having a character thereon, a search member bearing a set of all the different characters which may appear on such record, means for projecting by radiant energy upon said search member an image of the character appearing on the record, means for effecting relative movement of said search member and record to bring the various characters of said member into successive relation to such image, and a device operated by radiant energy when correspondence exists between a character on the search member and the character on the record.

22. A machine of the class described, comprising a manifesting device bearing a plurality of individual characters, a ray sensitive device, a movable device having a plurality of portions arranged to come into the path of rays of radiant energy and to modify said rays before they reach said ray sensitive device, and means, controlled by both of said devices, for controlling said manifesting device.

23. A machine of the class described, comprising a manifesting device bearing a plurality of individual characters, a ray sensitive device, a movable device having a plurality of individual characters corresponding to those of said manifesting device and arranged to come into the path of rays of radiant energy and to modify said rays before they reach said ray sensitive device, and means, controlled by both of said devices, for controlling said manifesting device.

24. A machine of the class described, comprising a manifesting wheel, a ray sensitive device, a comparison wheel having a plurality of characters arranged to come into the path of rays of radiant energy and to modify said rays before they reach said device, electromagnetic means for actuating said manifesting wheel, a circuit-controller movable with said comparison wheel, another circuit-controller controlled by said ray sensitive device, and an actuating circuit including said two circuit-controllers and said electro-magnetic means.

25. A machine of the class described, comprising a search member bearing a plurality of elements differing in ray-modifying properties, a carrier for an object to be compared with the elements of said search member, said member and carrier being relatively movable to establish a co-operative relation between the said object and different individual elements of the search member, a ray sensitive device located in the path of rays which have impinged on said object and on an element of the search member, a manifesting device, a controlling connection between said manifesting device and the search member, said connection including controlling means having relatively movable co-operating members connected respectively with said search member and said carrier, and said connection also including another controlling means, and an operative connection from the ray sensitive device to said last mentioned controlling means.

5 26. In combination, a search member having a series of different characters, means effective for each character on the search member for projecting the images of a series of characters of a record upon said search member, means controlled by radiant energy for comparing each character of the member with the images of each

of the characters on the record, and means for shifting said member after each comparison involving a character, to a position for comparing the same character of the record with a different character of the search member. 5

GUSTAV TAUSCHEK.