

L. N. NUTZ.
Calculator.

No. 21,236.

Patented Aug. 17, 1858.

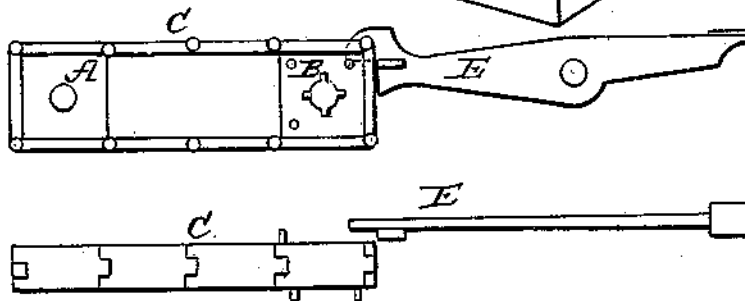
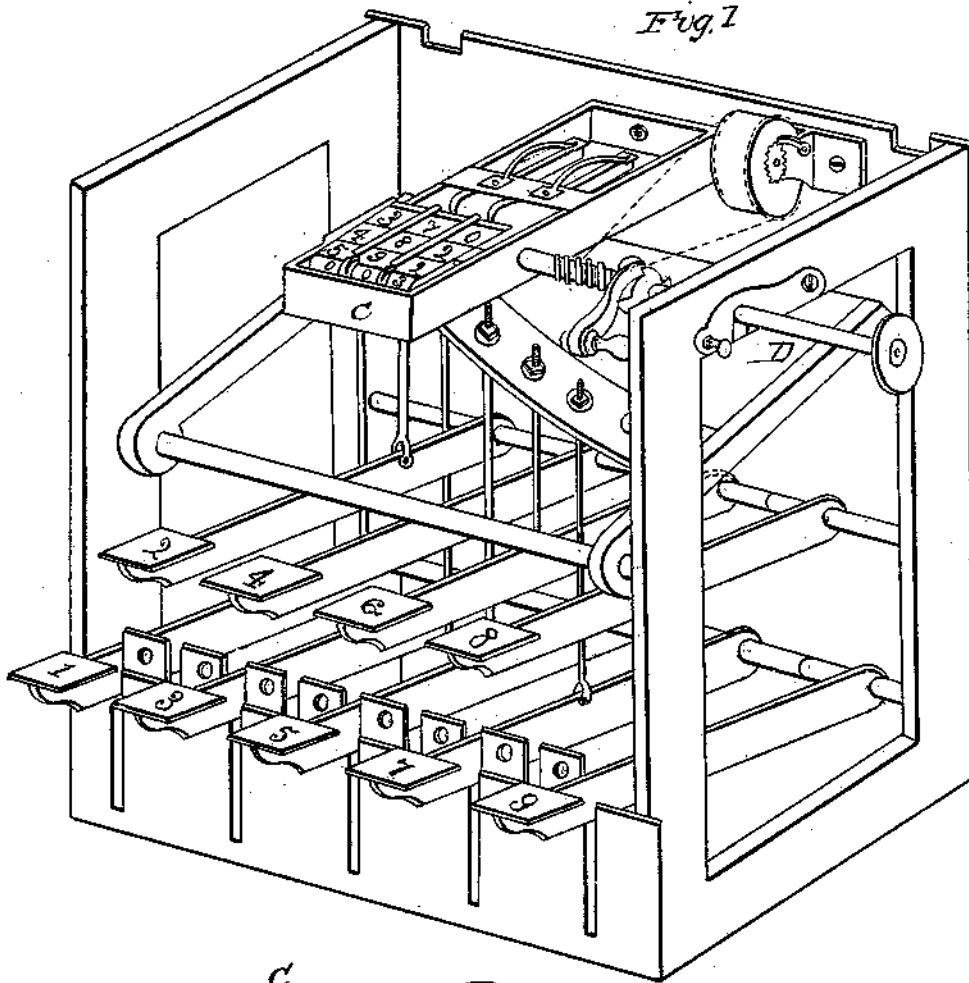

WITNESSES

J B Randle-gu
F. Nutz

INVENTOR

Leonard Nutz

UNITED STATES PATENT OFFICE.

LEONARD N. NUTZ, OF ALTON, ILLINOIS, ASSIGNOR TO IRWIN B. RANDLE
AND ELIAS HIBBARD.

IMPROVEMENT IN ADDOMETERS.

Specification forming part of Letters Patent No. 21,236, dated August 17, 1858.

To all whom it may concern:

Be it known that I, LEONARD N. NUTZ, of Alton, in the county of Madison and State of Illinois, have invented a new and useful Machine for Adding Numbers, called The "Addograph;" and I do hereby declare that the following is a full, clear, and exact description of the construction and operation of the same, reference being had to the annexed drawings, making a part of this specification.

Figure 1 is a perspective view of the whole machine with the top removed.

D is an adjustable shaft with one or more feather-keys thereon for the purpose of clutching and giving motion to the block of the indicator corresponding with the column you wish to add.

C C C are the indicators, which are endless chains passing over two square blocks and numbered on the separate links from 0 to 9, as on the wheels in other counting-machines. At intervals of every ten links is a pin *p* for the purpose of operating on the lever E, which in turn acts upon another pin on the rear side of the next indicator and moves it forward one link for every ten links that indicator the next preceding has been moved.

In Fig. 3 it may be seen how the pin *p* coming in contact with the projection *q* near the end of the lever E would bear down the end of said lever, and this, acting on the pin of the next chain, would press that down and thus move it forward one link.

The other parts of the machine by which the keys are made to give motion to the indicators have no essential novelty, and may be varied as in other machines for like purposes; but the blocks B (see Fig. 2) are all perforated with a round orifice large enough to allow the shaft D to pass through them, and grooves or slots are also cut in the block to receive the feathers on the shaft, which give motion to the block when the shaft turns.

It will be seen from the above that my invention relates to that class of machines which are used for making and registering the additions of long columns of figures by means of movable indicators acted upon by keys of a finger-board; and it consists in the arrangement and combination of the shaft

D, the blocks B, the indicators C, and the levers E, whereby each key communicates a proper and known motion to either of the indicators at the will of the operator, and the result is accurately registered by the indicator corresponding to the column wherein the addition is being made.

The operation of the machine is as follows: The endless chains being arranged with the ciphers opposite the opening in the cover and the shaft D being adjusted so as to clutch the block B of the indicator corresponding with the column of units, the key which corresponds to the first figure in the unit-column is depressed as far as it will go, then that one corresponding to the second figure, and so on through the column of units. Each time a key is depressed the endless chain corresponding to the units-column will be moved forward a distance corresponding to the number of the key depressed, and every time ten is counted on this chain a projection on the side of it operates a lever, which in turn presses on a projection on the side of the next chain, which is thereby fed forward one number for every ten in the units-column. When the addition of the column of units is completed, the catch K is lifted from the shaft D and the shaft pushed in, so as to clutch the block B of the indicator of the column of tens. The catch K is then let down again in the next notch of the shaft D. The indicator of the column of tens is then in gear with the keys of the finger-board, and the addition of this column is proceeded with in like manner to that of the column of units, the indicator of hundreds being advanced one for every ten of the indicator of tens. By thus continuing to change the connection between the shaft D and the indicators from the one corresponding to the column where the addition is completed to the next following any number of columns may be added up and registered by the use of the same set of keys.

I am aware that machines with a series of circular indicators and a corresponding number of set of keys have been made to effect the same purpose; but in these there were no means of connecting or disconnecting at pleasure the keys and the several wheels, so as to

make the same set of keys register in turn the additions of the several columns. I therefore do not claim, broadly, registering the result of the additions of figures in columns by means of movable indicators acted upon by the keys of a finger-board; but

What I do claim as new is—

The feathered shaft D, when combined and arranged with a series of indicators and a set

of keys, substantially as above described, for the purpose of enabling the operator to add up and register any number of columns of figures in succession by means of the same set of keys.

LEONARD N. NUTZ.

Witnesses:

J. B. RANDLE, Jr.,

JOHN A. MOXEY.